

SIMG

SIGNAL ISOLATOR (KB P/N 8832)

For Model KBMG-212D

Provides an Isolated Interface
between Non-Isolated Signal Sources
and the KBMG Regenerative Drive



STANDARD FEATURES

- Multi-Turn trimpots for OFFSET & MAX Speed Adjustment.
- Accepts a Wide Range of Voltage Input Signals.
- LED for Power On (PWR) Indication.
- Barrier Terminal Block Facilitates Wiring (removable).
- Protective Cover for Added Safety.

SPECIFICATIONS

Voltage Following Operation Input Range (V DC)	±5 – ±25
Potentiometer Operation (KΩ)	5
OFFSET Trimpot Range (with 0V DC Input) (% Full Speed)	±50
MAX Trimpot Range (with 10V DC Input) (% Full Speed)	110
Input Switch Type	Dry Contact or Open Collector
Linearity (%)	0.1
Thermal Drift (mV/°C)	0.15
Response Time (step) (ms)	30
Ambient Operating Temperature Range (°C)	0 – 50

CONNECTION DIAGRAMS

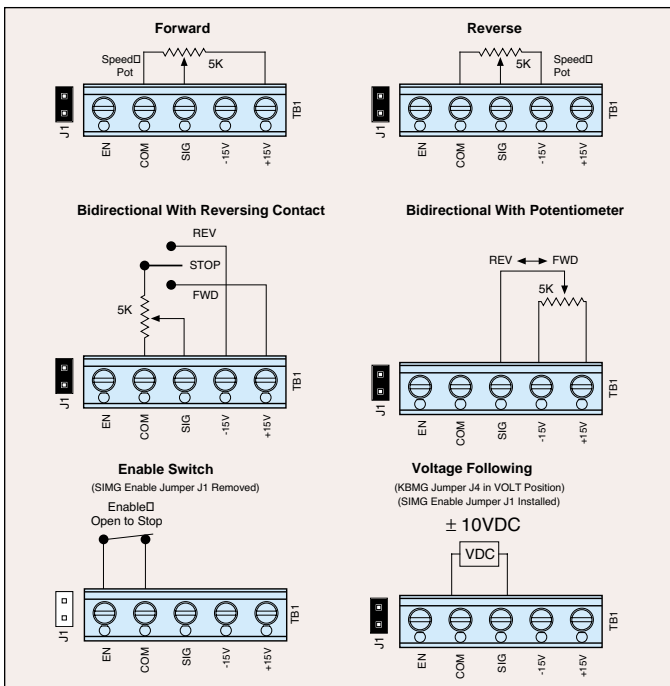

DESCRIPTION

The SIMG (KB P/N 8832) is used to isolate, amplify, and condition DC voltage signals from any source (power supplies, motors, tachometer generators, transducers, and potentiometers) to control the KBMG-212D Regenerative Drive (P/N 8831). In addition, it provides an isolated input for motor direction and an isolated power supply for transducer or potentiometer operation.

Input connections (+15V, -15V, SIG, COM, and EN) are made via a barrier terminal block and are isolated from AC line and motor wiring.

The SIMG is factory calibrated to accept a signal input voltage of -10V to +10V DC. OFFSET and MAX trimpots are provided in order to recalibrate the SIMG for a specific application.

CONTROL LAYOUT & MECHANICAL SPECIFICATIONS

