

KBRF-250

CLASS A INDUSTRIAL RADIO FREQUENCY INTERFERENCE (RFI) FILTER

Part No. 9509

for Use with Adjustable Frequency Drives
and Other Speed Controls*

Meets CE Requirement EN55011 for RFI
Suppression on Motor Speed Controls
for Industrial Applications**

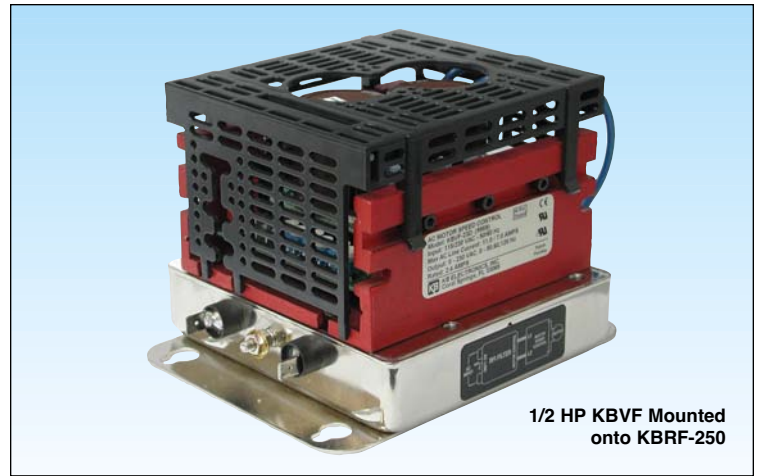

1/2 HP KBVF Mounted
onto KBRF-250

MECHANICAL SPECIFICATIONS (INCHES / [mm])

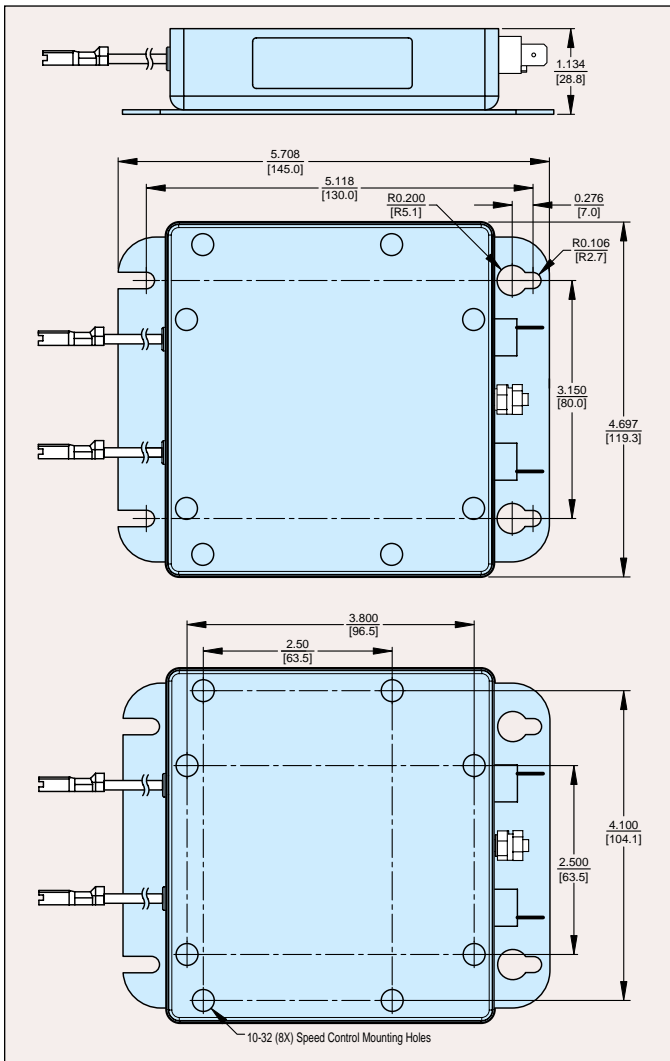

SPECIFICATIONS

10 Amps AC Maximum – 230 VAC – 50/60 Hz	
Temperature Operating Range	0 – 50 °C
Frequency Range	150 kHz – 30 MHz Per CE Specification EN55011
Earth Leakage	2.0 mA @ 250 VAC/50 Hz

DESCRIPTION

The KBRF-250 is an RFI filter used to suppress electronic interference caused by motor speed controls. These controls utilize SCR or transistors that switch on and off rapidly causing high frequency interference pulses. These pulses are easily transmitted through the AC power lines which can then enter other equipment wired to the same line. In addition, once the interference is allowed to conduct through the power lines, the wires become radio antennas, which actually radiate electromagnetic energy through the air. The energy, whether conducted or radiated, is called Radio Frequency Interference (RFI) and is most pronounced between the frequency range of 0.5 MHz – 1.5 MHz, which is the AM broadcast band. Although the interference is usually not noticeable, except for static on an AM radio, it could affect sensitive electronic equipment in some instances. The KBRF-250 is an RFI filter which has been designed to limit the interference to within acceptable levels as determined by CE Directive 89/336/EEC relating to the EMC Class A Industrial Standard.

The KBRF-250 is primarily designed as an integral mounting base for speed controls with industry standard mounting requirements such as the KBVF Series Inverter, PWM DC Speed Controls, and SCR Speed Controls. An array of eight (8) threaded (10-32) mounting holes are provided to mount various speed controls. Installation is easily accomplished with quick-connect terminals. It is housed in a plated steel case which is to be grounded with the external ground screw or mounting tab.

CONNECTION DIAGRAM

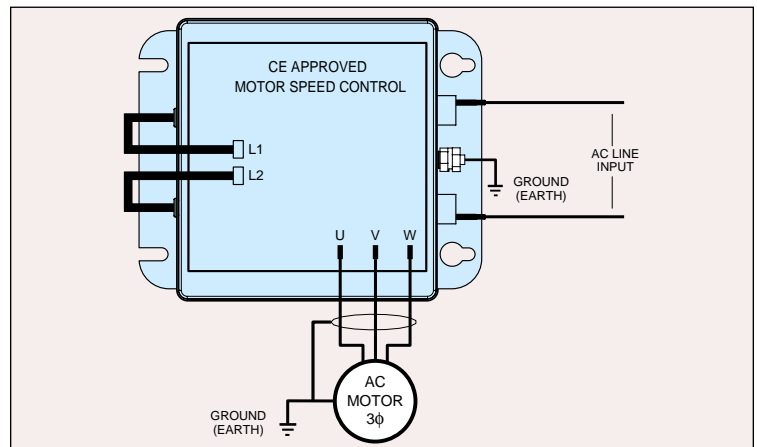

* Designed as an integral mounting base for speed controls with industry standard mounting requirements such as the KBVF Series Inverter, PWM DC Speed Controls, and SCR Speed Controls.
** When installed in accordance with the procedures outlined, the motor speed control will comply with CE Directive 89/336/EEC relating to the EMC Class A Industrial Standard.